

PERSPECTIVE

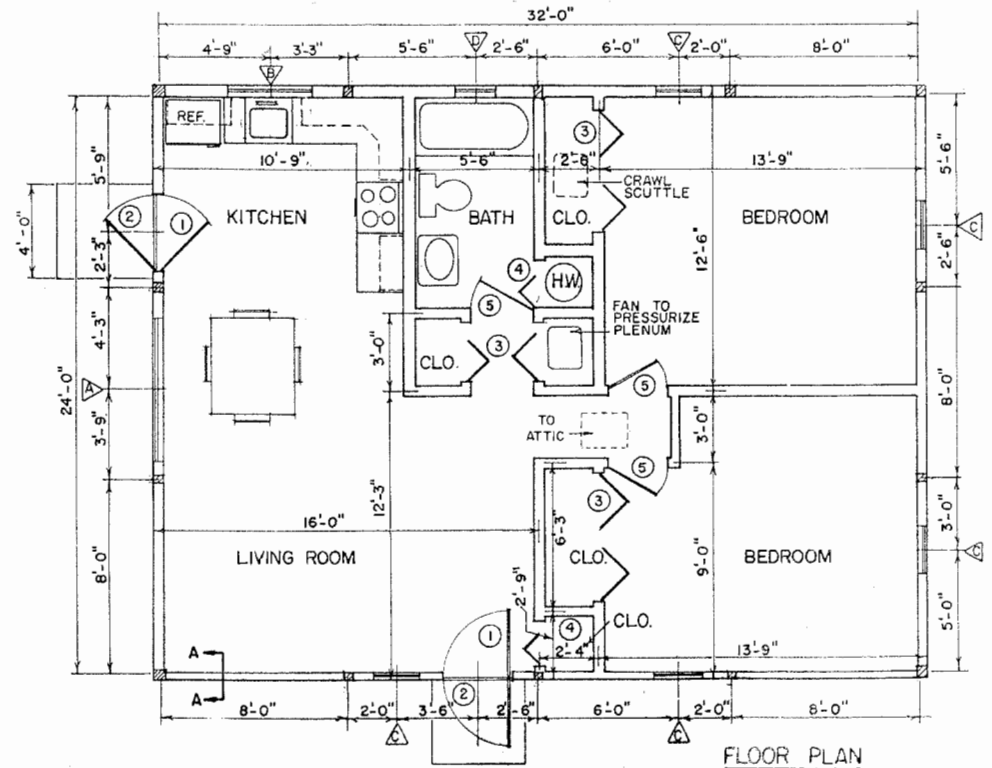

FLOOR PLAN

12" 0' 1' 2' 4'  
 SCALE 1/4" = 1'-0"

DOOR SCHEDULE		
NO.	DESCRIPTION	NO.
1	3'-0" x 6'-8" SOLID EXT.	2
2	3'-0" x 6'-8" STORM	2
3	2'-6" x 6'-8" BI-FOLD	6
4	2'-0" x 6'-8" BI-FOLD	2
5	2'-6" x 6'-8" HOLLOW INTERIOR	3

WINDOW SCHEDULE		
NO.	DESCRIPTION	NO.
A	3'-0" x 4'-2" WOOD DOUBLE-HUNG	2
B	3'-0" x 2'-10" WOOD DOUBLE-HUNG	2
C	2'-0" x 4'-2" WOOD DOUBLE-HUNG	6

NOTE: COORDINATE WINDOW SIZE WITH FRAMING.

768 SQ FT HEATED AREA.

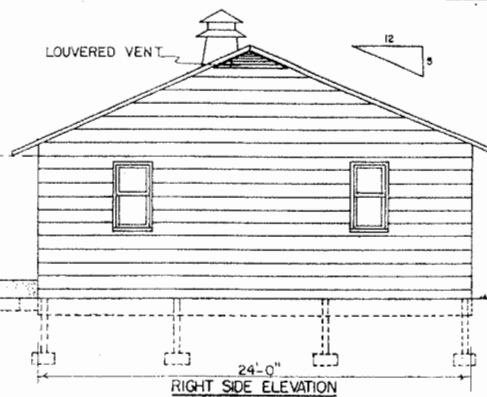
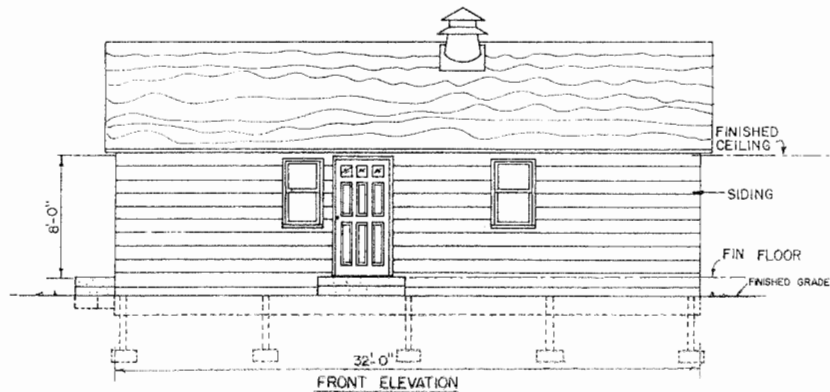

SCALE 3/16" = 1'-0"

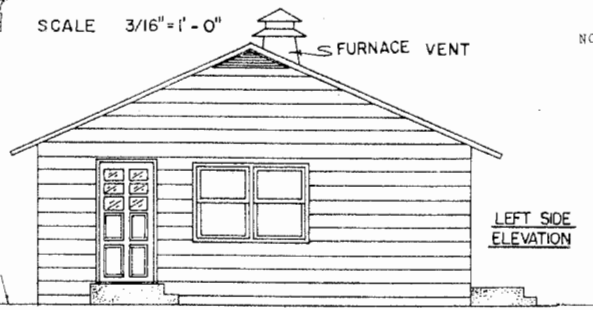
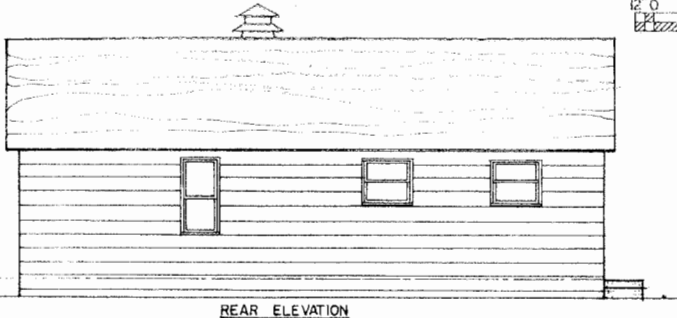

POLE CABIN w/ PLENUM HEATING

USDA '66 5997 SHEET 1 OF 2

REV '88

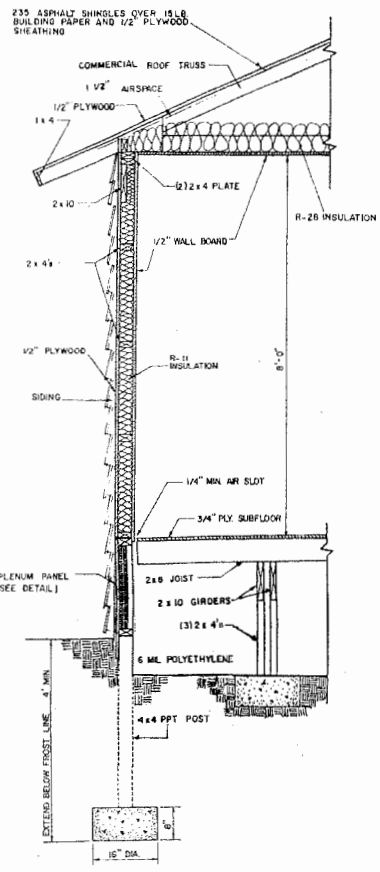

**SECTION A-A**

SCALE 1/2" = 1'-0"

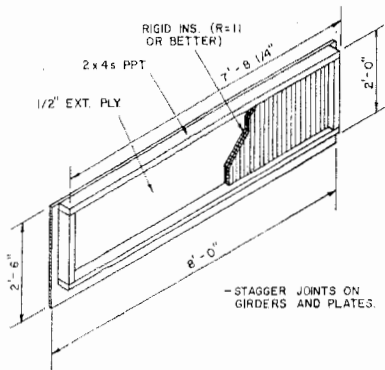

**PLENUM PANEL DETAIL**  
(NO SCALE)

NOTE:

IF PLENUM CHAMBER IS NOT USED AND AREA UNDER HOUSE IS LEFT OPEN CRAWL SPACE, FLOOR WILL NEED INSULATION AND FLOOR FOOTINGS MAY NEED TO BE EXTENDED BELOW FROST LINES.

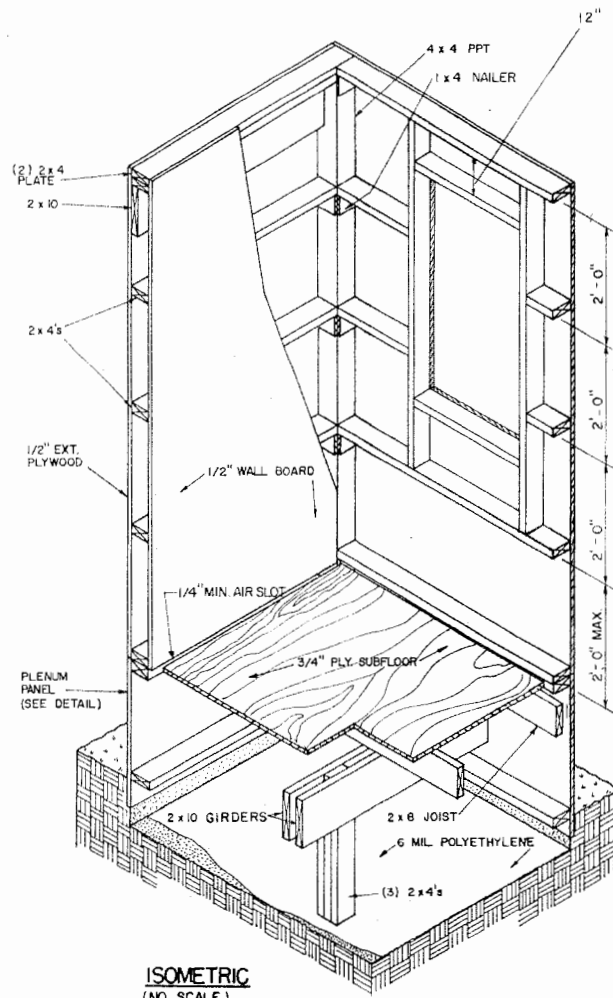

**ISOMETRIC**  
(NO SCALE)

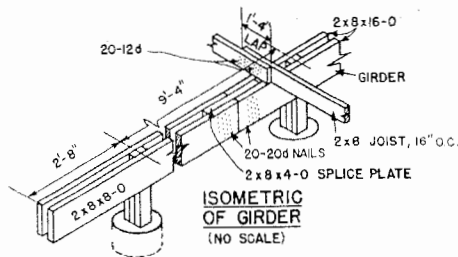

**ISOMETRIC OF GIRDER**  
(NO SCALE)

NOTE: HOT AIR IS FED TO PLENUM BY DOWN DRAFT FURNACE. ROOMS ARE FED THROUGH SLOTS BETWEEN FLOOR AND OUTSIDE WALLS.

12" STD. COORDINATE FRAMING WITH WINDOW CHOICES.

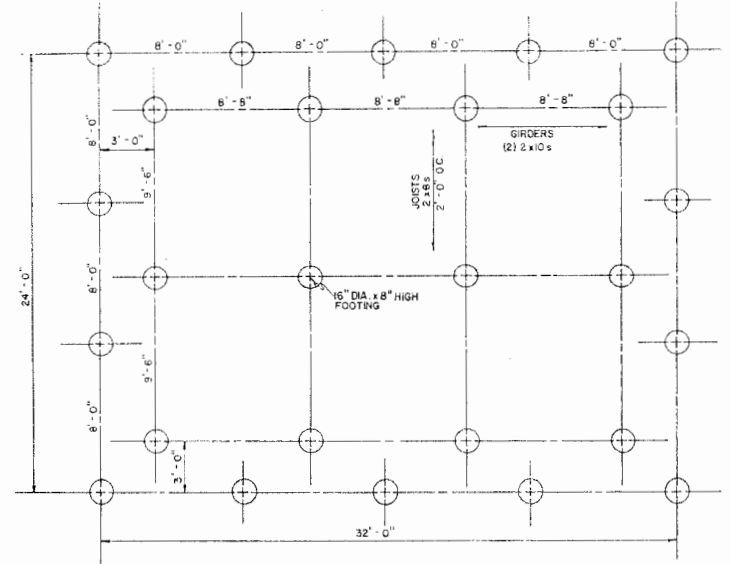

**FOUNDATION PLAN**

SCALE 3/16" = 1'-0"

NOTE: PLACE OUTSIDE POLES FIRST BUT DO NOT TAMP TOO SOLIDLY IN PLACE UNTIL 2x10 BEAM AND PLATES ARE IN PLACE AND TRUSSES ARE SECURELY ANCHORED TO PLATE. FLOOR FRAMING IS BEST PUT IN PLACE AFTER ROOFING AND SHEATHING.

**CONSTRUCTION CHECK LIST**

1. CHECK LOCAL BUILDING CODE AND LOAN COMPANY CRITERIA. PURCHASE TRUSSES TO MEET LOCAL SNOW LOAD CRITERIA.
2. ADEQUATELY NAIL AND ANCHOR JOINTS.
3. DOUBLE JOISTS UNDER TUBS AND OTHER HEAVY LOADS.
4. SHEATH CORNERS WITH 1/2" PLYWOOD OR HIGH DENSITY FIBERBOARD OR USE DIAGONAL BRACING.
5. USE EXTERIOR GLUED PLYWOOD WHEREVER IT MAY BE WETTED DURING OR AFTER CONSTRUCTION.
6. PRESSURE TREAT ALL WOOD WITH GROUND CONTACT AND PROVIDE OTHER NEEDED TERMITE CONTROL.
7. R VALUES DEPEND ON LOCAL CLIMATE AND FUEL COSTS.
8. PROVIDE 1 SQ FT OF ATTIC VENT OPENINGS FOR EACH 150 SQ FT OF CEILING.
9. WEATHERIZE ALL OPENINGS AND JOINTS.



**POLE CABIN w/ PLENUM HEATING**

USDA '66 5997 SHEET 2 OF 2

REV 88

## Disclaimer

This site makes available conceptual plans that can be helpful in developing building layouts and selecting equipment for various agricultural applications. These plans do not necessarily represent the most current technology or construction codes. They are not construction plans and do not replace the need for competent design assistance in developing safe, legal and well-functioning agricultural building system. The LSU Agriculture Center, the Mid-West Plan Service, the United States Department of Agriculture and none of the cooperating land-grant universities warranty these plans.